

[CONTRIBUTION FROM GATES CHEMICAL LABORATORY, CALIFORNIA INSTITUTE OF TECHNOLOGY, No. 164]

THE QUANTUM YIELD IN THE PHOTOCHEMICAL DECOMPOSITION OF NITROGEN DIOXIDE

BY ROSCOE G. DICKINSON AND WARREN P. BAXTER

RECEIVED JANUARY 6, 1928

PUBLISHED MARCH 7, 1928

Introduction

In a paper on "Photochemical Equilibrium in Nitrogen Peroxide," Norrish¹ has described experiments in which a pressure increase was observed when NO_2 in a quartz vessel was illuminated by a quartz mercury vapor lamp. Under illumination the pressure increased rapidly at first, then more slowly, and reached a sensibly constant value after about fifteen minutes. When the illumination was cut off, the pressure dropped rapidly at first and then approached its original value comparatively slowly. The pressure increase could not be accounted for by heating alone. Norrish assumed that NO_2 was decomposed photochemically into NO and O_2 ; constancy of pressure was then attained when the rate of recombination of NO and O_2 became equal to the rate of photodecomposition of NO_2 . This assumption received confirmation from the results of experiments carried out at various NO_2 pressures and with NO or O_2 initially present. Both of these gases cut down the pressure increase, and the NO did so more effectively than the O_2 , as was expected from the fact that the rate² of recombination is proportional to $p_{\text{NO}}^2 p_{\text{O}_2}$.

In the present paper are described first some qualitative experiments which test further the correctness of Norrish's view that NO_2 is photochemically decomposed into NO and O_2 , and then some measurements on the quantum yield of the reaction with monochromatic light. In contrast with the previous work, the present experiments were carried out under conditions where recombination should be negligible. Since the recombination is a third-order reaction, its rate becomes small at low pressures; for example, at $p_{\text{O}_2} = 0.04$ mm. and $p_{\text{NO}} = 0.08$ mm., the rate of decrease of p_{O_2} may be calculated from the measurements of Bodenstein and Lindner to be only 2.4×10^{-5} mm./hour at 22° . Hence, by keeping the pressures of the reaction products sufficiently small, it might be possible to treat the reaction simply as a photochemical decomposition rather than as a photochemical equilibrium. In order to measure the small amount of reaction product present in the larger amount of NO_2 used to secure sufficient light absorption, the NO_2 was frozen out with liquid air, and the residual gas measured with a quartz fiber gage,³ the

¹ Norrish, *J. Chem. Soc.*, 1927, 761.

² Bodenstein and Lindner, *Z. physik. Chem.*, 100, 87 (1922).

³ Haber and Kerschbaum, *Z. Elektrochem.*, 20, 296 (1914); Coolidge, *THIS JOURNAL*, 45, 1637 (1923).

use of this procedure under similar circumstances having already been found convenient.⁴ Measurements of a small amount of product also facilitate the use of relatively weak monochromatic light sources.

This investigation was aided financially from a grant made to Professor A. A. Noyes by the Carnegie Institution of Washington.

The Apparatus

A diagram of the experimental arrangements is shown in Fig. 1. The reaction chamber, A, was a Pyrex tube 20 cm. long and 3.2 cm. internal diameter with plane end windows fused on. Always in communication

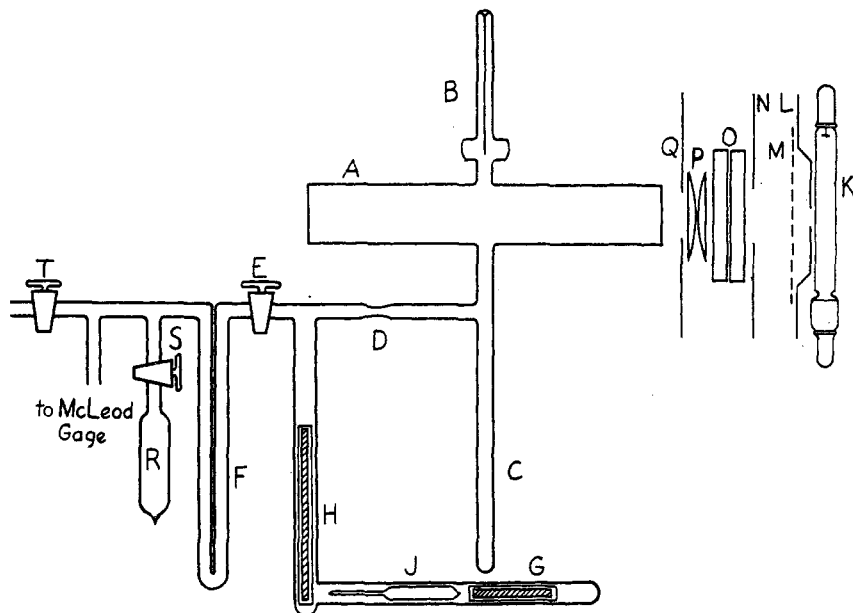

Fig. 1.

with this was the bifilar quartz fiber gage, B. The side tube, C, could be immersed in liquid air. This much of the apparatus up to the constriction, D, could be surrounded by a furnace for baking out during evacuation. The stopcock, E, led through the liquid air trap, F, to a McLeod gage, mercury vapor pump, etc. The glass enclosed iron rods, G and H, were used respectively for magnetically moving the tube, J, and breaking off its capillary end.

Light from the mercury arc, K, operated from a storage battery, passed through a hole 1 cm. in diameter in the diaphragm, L. When the shutter, M, was raised, the light passed through the diaphragm, N, the filters, O (described below), and was rendered slightly convergent by the glass

⁴ Dickinson and Mitchell, *Proc. Nat. Acad. Sci.*, 12, 692 (1926).

lenses, P. The diaphragm, Q, defined the beam entering the reaction chamber; the beam was adjusted to travel the length of the chamber without striking the walls.

The calibration curve for the fiber gage was determined with the aid of the McLeod gage using air, oxygen and at the lower $p\sqrt{M}$ values hydrogen. One fiber gage which we attempted to use showed an unaccountably erratic behavior. Its readings could be markedly altered, for example, by leaning objects against certain parts of the glass apparatus; it seemed as if the vibration period of the gage were in resonance, or nearly so, with some period in the glassware. The gage with which the measurements reported were made was watched carefully and appeared to be free from these difficulties. It had a half-period of 271 seconds at 10^{-3} mm. of O_2 , and 18.2 seconds at 4×10^{-2} mm.; nearly all of the measurements were made in this range.

The Materials

The nitrogen dioxide was prepared by heating c. p. lead nitrate in an all-glass apparatus, passing the gas evolved over P_2O_5 and condensing it in a trap cooled by an ice-salt mixture. After condensation of sufficient NO_2 , the generating apparatus was sealed off. In preparation for use, the NO_2 was vaporized through a tube containing P_2O_5 and then through a series of small tubes with drawn-out capillary ends; when completely swept out by NO_2 at atmospheric pressure, these were quickly sealed off. The temperature and barometer reading at the time of sealing off were noted and the volumes of the tubes measured later.

The nitric oxide was prepared by the action of mercury on a solution of sodium nitrite in sulfuric acid.⁵ The gas was passed over caustic soda, then over P_2O_5 and sealed up in small bulbs.

Tank oxygen was used without other purification than the use of liquid air to remove water vapor.

Tank hydrogen was stored in contact with metallic sodium.

Nitrogen was prepared by heating sodium trinitride.

Preliminary Experiments

The following experiments were made to determine whether a gas non-condensable by liquid air was produced by the illumination of NO_2 , as expected, to determine its composition and to ascertain whether its quantity could be used as a measure of the extent of decomposition.

1. The reaction vessel was evacuated and baked out up to the point D. With liquid air applied at C and with the cock, E, closed, a tube, J, containing NO_2 was broken. The cock was opened, traces of uncondensed gas were pumped off and the apparatus was sealed off at D. Enough NO_2 was used to give about 7 mm. pressure at room temperature. The fiber

⁵ Emich, *Monatsh.*, 13, 73 (1892).

gage was read, the liquid air removed and the apparatus allowed to stand for fifteen minutes in the dark. The liquid air was then replaced and the gage again read. This was done to insure the absence of any unsuspected source of pressure development. The liquid air was again removed and the chamber illuminated for six minutes with the mercury arc without filters, lenses or diaphragms. On replacing the liquid air the pressure was found to be too high to measure and was probably at least 0.15 mm. This experiment showed that a non-condensable gas was indeed produced by illuminating NO_2 .

2. Because of the high vapor pressure of liquid NO, gaseous NO alone would not be condensed out by liquid air at the pressures involved here; but in the presence of an excess of NO_2 , it might condense out as N_2O_3 or otherwise. To determine whether this occurred, a tube, J, containing enough NO_2 to give a final pressure of 2.8 mm. was introduced and a smaller tube containing NO placed in a second side arm (not shown). The apparatus was prepared and the NO_2 admitted as above, but D was not sealed off. (Separate experiments showed that in these brief experiments the stopcock, E, did not give trouble with NO_2 .) With the cock closed the fiber gage was read and the NO then admitted. The gage readings then gave 0.11 mm. of NO. The liquid air was next removed, the NO_2 allowed to vaporize in the dark and the liquid air immediately replaced. The gage showed then as good a vacuum as before the admission of the NO. From the results of such experiments it was concluded that the non-condensable gas produced by the illumination of NO_2 would not contain an appreciable amount of NO.

3. To show that the non-condensable gas was oxygen rather than nitrogen, a side bulb, R, was sealed on and sodium distilled into it *in vacuo* from a second bulb which was then sealed off. Blank experiments showed that oxygen quickly cleaned up when admitted to this bulb through S, whereas nitrogen cleaned up not more than 1%, if at all, in five minutes. The whole apparatus was evacuated and NO_2 transferred from J to C as usual. With stopcock E closed, the liquid air was removed from C and the chamber illuminated for two minutes without filters. The liquid air was replaced on C, and E was opened with S closed. The McLeod gage read 0.14 mm. (total volume of gas about 500 cc.). When the gas was admitted to the small sodium bulb by opening S, the pressure dropped to less than 10^{-4} mm. in three minutes. Experiments also were performed using only the radiation λ 3660 Å., with similar results.

4. These experiments are in agreement with and afford confirmation of Norrish's interpretation of the pressure rise on illumination of NO_2 as being due largely to decomposition of NO_2 into NO and O_2 . In order to be able to use the residual oxygen pressure as a measure of the extent of decomposition, it was necessary to be sure that no important amount

of oxygen was removed by the solid N_2O_4 at liquid air temperature. The entire apparatus was evacuated; with liquid air at both F and C, and with E closed, about 0.1 mm. of oxygen was admitted to the McLeod gage system and T closed. Readings of the McLeod gage were made, E was opened and readings were again made. The experiment was then repeated, a considerable quantity of NO_2 having been first condensed in C in the usual manner. Then with E closed, the NO_2 was vaporized from and recondensed in C in the presence of the oxygen; E was opened and the McLeod gage read. The ratio of the initial to the final pressures (about 2.11) was the same to 2% in all cases. Therefore little if any oxygen was removed by the NO_2 .

Measurement of Quantum Yield

Previous to each experiment on the quantum yield, the reaction chamber, fiber gage and tube C were evacuated and baked out for several hours without liquid air, and then for a further period with liquid air at F. Then liquid air was applied at C, the stopcock, E, was closed, and a tube, J, containing NO_2 was opened; the NO_2 immediately froze out in C. The cock, E, was opened to pump off any residual gas and the apparatus was sealed off at D. The reaction chamber and accessories were then surrounded by a box which was light tight except for provision for admitting the desired radiation. When the NO_2 was subsequently allowed to vaporize for illumination, it came into contact with only glass and quartz. The temperature was not controlled but was always within a degree of 22° .

Three different filter combinations were used to monochromatize the light. Common to all of these was a 1-cm. layer of 6% cupric sulfate solution to remove infra-red.⁶ To isolate the blue, λ 4350Å., 4 mm. of Corning glass G585 and 2 mm. of Noviol A were used; for the violet, λ 4050Å., 5 mm. of G586A and 1 cm. of a 4% solution of quinine hydrochloride; for the ultraviolet, λ 3660Å., 9 mm. of G586AW. Mercury arc spectra transmitted by these filters were photographed with various exposure times. The blue radiation contained only the blue Hg lines; the violet radiation contained far less than 1% of the groups at 3650 and 4350; the ultraviolet was free from the lines at 4050 but contained a few per cent. of the wave length 3350.

The intensity of the light entering the reaction chamber was measured in the following manner. At the beginning and end of each illumination the reaction chamber was moved aside and a Moll thermopile with an aperture 6 mm. in diameter was placed in its stead at the center of the diaphragm, Q; the thermopile was connected with a sensitive, low resistance, reflecting galvanometer and a series of measurements of the change

⁶ Coblenz, *Bur. Stand. Bull.*, 9, 110 (1913).

in deflection when the shutter M was opened and closed (by remote control) was made. In these measurements, but not in the calibration, the aperture of the thermopile was covered with a slip of the same glass used for the reaction-chamber window; this automatically corrected for reflection loss. The slight non-linearity of the galvanometer scale was calibrated by measuring the deflections corresponding to small potentials imposed on the galvanometer by a suitable high resistance potentiometer arrangement. The corrected galvanometer deflection produced when the thermopile was placed in a beam of given intensity was determined with the aid of a carbon filament lamp calibrated by the Bureau of Standards; the detailed directions given for the use of this lamp as a radiation standard were followed. The beam entering the reaction chamber was not entirely uniform in intensity over the diaphragm; by taking, in a separate experiment, readings with the thermopile in front of various parts of the diaphragm, a factor was determined to reduce the intensity at the center of the diaphragm to the average intensity over the diaphragm.

Several successive illuminations with corresponding measurements of light intensity and oxygen pressure were made on each sample of NO_2 . As the half period of a fiber gage is more sensitive to pressure changes the lower the pressure, the first illuminations on a given sample were always briefer than the subsequent ones.

The fraction of the light transmitted by the NO_2 was measured at the end of the experiment by placing the thermopile in a fixed position at the rear of the reaction chamber and observing the change in galvanometer deflection when the shutter was operated both with and without liquid air applied at C. One minus the ratio of these deflections gave the fraction of light absorbed.

At the end of some of these runs (including No. 12, which had the highest final pressure), the apparatus was allowed to stand in the dark for about fifteen hours without liquid air; after replacing the liquid air at the end of this interval, no detectable change in the pressure of the non-condensable gas was observed.

The Experimental Results

In the accompanying table are given the results of all our quantum yield determinations except some with blue light which were found to be unreliable because of stray light and an erratic fiber gage. The partial pressures of NO_2 and N_2O_4 present at the time of illumination were calculated from the volume and temperature of the reaction vessel, the volume of the bulb, J, together with the temperature and barometer reading at the time of sealing it off, and the constant⁷ for the equilibrium between NO_2 and N_2O_4 . The yield tabulated in the last column is the number

⁷ Schreber, *Z. physik. Chem.*, **24**, 651 (1897).

TABLE I
 QUANTUM YIELD DETERMINATIONS

No.	Wave length, Å.	p_{NO_2} , mm.	$p_{N_2O_4}$, mm.	Fraction of light absorbed	p_{O_2} , initial, mm.	p_{O_2} , final, mm.	Δp_{O_2} , mm.	Exposure time, min.	Galv. deflect., cm.	Yield	
5	4350	5.8	0.40	0.902	0.00303	0.00697	0.00394	87.0	8.22	0.0045	
						.00697	.01246	.00549	129.0	7.50	.0047
						.01312	.02369	.01057	178.0	8.24	.0059
									Mean		.0050
6	4350	14.2	2.4	.986	.00008	.00691	.00683	147.0	8.90	.0039	
						.00691	.01691	.01000	227.0	8.34	.0040
									Mean		.0040
12	4050	3.5	0.15	.753	.00024	.00472	.00448	10.00	3.07	.359	
						.00472	.01073	.00601	15.00	2.84	.348
						.01073	.02417	.01344	35.00	2.73	.346
						.02417	.04342	.01925	55.00	2.56	.337
									Mean		.348
11	4050	11.1	1.5	.994	.00055	.00791	.00736	5.00	3.12	.376	
						.00791	.01332	.00541	4.00	2.93	.369
						.01332	.02643	.01311	10.00	2.80	.374
									Mean		.373
8	3660	3.5	0.15	.748	.00064	.00558	.00494	5.00	3.42	.792	
						.00558	.01112	.00554	6.51	3.08	.757
						.01112	.02393	.01281	15.00	2.91	.804
									Mean		.784
7	3660	9.3	1.0	.982	.00000	.00729	.00729	2.01	4.41	.739	
						.00729	.01442	.00713	2.00	4.17	.767
						.01442	.03177	.01735	5.00	3.85	.808
									Mean		.771
10	3660	10.9	1.4	.988	.00093	.00600	.00507	5.00	2.68	.784	
						.00600	.01446	.00846	9.00	2.42	.805
						.01446	.02961	.01515	18.00	2.21	.790
									Mean		.793
9	3660	39.7	18.7	.993	.00219	.00711	.00492	5.00	2.78	.729	
						.00711	.01343	.00632	7.00	2.61	.714
						.01343	.02504	.01161	13.00	2.48	.742
									Mean		.728

of molecules of oxygen produced per quantum absorbed and was obtained from the following formula,

$$\text{Yield} = \frac{N \cdot r \cdot \Delta p \cdot v}{RT} \left(\frac{d \cdot 10^7 \cdot b \cdot A \cdot i \cdot a \cdot 60 \cdot 10^{-8} \lambda}{hc} \right)^{-1}$$

The factor outside the parentheses is the number of molecules of oxygen produced; the factor within is the corresponding number of quanta absorbed. The symbols have the following significance

- N = the Avogadro number, 6.062×10^{23}
- Δp = increase in oxygen pressure, mm. of Hg
- v = volume of reaction system, 193 cc.
- T = absolute temperature, between 294 and 296° in different experiments
- R = gas constant, 82.07×760 mm.-cc./degree
- r = a correction factor, 1.06, to correct for the fact that 4.5 cc. of the gas was at liquid air temperature

- d = mean corrected galvanometer deflection, cm. of scale
 b = light intensity to give one centimeter of corrected scale deflection, 11.54×10^{-8} watts/sq. mm.
 A = area of diaphragm in square millimeters; 707 in Expts. 5, 6, 7, 11; 280.5 in Expts. 8, 9, 10, 12
 i = factor to reduce intensity at center of diaphragm to average intensity over diaphragm; 0.84 in Expts. 5, 6, 7, 11; 0.91 in Expts. 8, 9, 10, 12
 a = fraction of radiation absorbed
 t = time of illumination, minutes
 λ = wave length of radiation, Å.
 h = Planck's constant, 6.554×10^{-27} erg-secs.
 c = velocity of light, 3.00×10^{10} cm./sec.

Discussion of Results

Successive illuminations of a single sample do not show definitely an increase or decrease of yield. This fact affords an additional presumption that the measurements are not seriously in error from such causes as thermal dissociation, recombination or adsorption of oxygen.

In the range of pressures studied, the yields are not markedly dependent on the pressures of NO_2 and N_2O_4 . In the determinations with λ 3660Å. the NO_2 pressure was varied 11-fold; the corresponding variation in the N_2O_4 pressure was 125-fold.

The yield is, however, greatly dependent on the wave length of the radiation. The radiation λ 4350Å. is comparatively ineffective, while the radiation λ 3660Å. gives a yield only 23% less than that to which Norrish's mechanism would lead if all the radiation of this wave length produced reaction. The first step in this mechanism is assumed to be the production of a nitrogen dioxide molecule⁸ in a higher quantum state, NO_2' , by the absorption of a quantum by NO_2 . The second step is assumed to be $\text{NO}_2' + \text{NO}_2 = 2\text{NO} + \text{O}_2$. In the absence of degradation to heat, or of other loss of the excitation energy, this would lead to the production of one molecule of oxygen per quantum absorbed or a yield of unity.

Two possible explanations suggest themselves for the rapid increase in yield in the neighborhood of λ 4100Å.: (1) Reaction between an excited NO_2 and a normal molecule can take place only when the excitation exceeds a critical energy value, ϵ_0 . When the quantum supplied has less energy than ϵ_0 , the deficit must be made up from thermal energy; as the deficit will be larger at longer wave lengths, in fewer cases will the thermal energy be sufficient to make it up. However, it is doubtful whether the observed increase in yield with frequency is sufficiently sharp to be accounted for in this manner. (2) The probability that an excited

⁸ Norrish has pointed out that dissociation of NO_2 as a primary process would require the production of an atom of either oxygen or nitrogen; in view of the high energy content of either of these atomic forms, there is not sufficient energy available to permit a dissociation process. That a quantized state is the first result of absorption follows also from the well-known fact that the absorption spectrum is discontinuous. Absorption spectra which we have photographed show this to be true not only in the visible but also in the neighborhood of λ 3660Å.

NO_2 will on collision undergo reaction rather than thermal degradation increases rapidly as its excitation increases in the neighborhood of 70,000 calories per mole (corresponding to violet light).

Summary

Experiments are described which are in confirmation of Norrish's view that gaseous NO_2 is decomposed by light into NO and O_2 . By employing a technique permitting experimentation at sufficiently low partial pressures of NO and O_2 , recombination of these gases could be made slow enough to neglect. This permitted quantum yield determinations to be made treating the reaction simply as a decomposition rather than as a photochemical equilibrium. For the quantum yields, expressed as molecules of oxygen produced per quantum absorbed, the following mean values were obtained: λ 4350Å., 0.0046; λ 4050Å., 0.36; λ 3660Å., 0.77. These yields were found to be not markedly dependent on the pressure in the range studied.

PASADENA, CALIFORNIA

[CONTRIBUTION FROM THE CHEMISTRY DEPARTMENT OF IOWA STATE COLLEGE]
THE DECOMPOSITION OF POTASSIUM CHLORATE. III. THE EFFECT OF PRESSURE ON THE DECOMPOSITION OF POTASSIUM CHLORATE-MANGANESE DIOXIDE MIXTURES¹

H. M. McLAUGHLIN WITH F. E. BROWN

RECEIVED JANUARY 9, 1928

PUBLISHED MARCH 7, 1928

The decomposition of potassium chlorate is considered irreversible under any attainable conditions. Lewis and Randall^{1a} report that they heated potassium chlorate in a closed steel bomb 1.5 inches in external diameter in which a 0.75 inch hole was bored. After 0.5 hour at 400° the bomb had become bulb shaped. By an indirect method (the comparison of free energies) they calculated that potassium chlorate decomposing at room temperature would be in equilibrium with oxygen under a pressure of about 10^{15} atmospheres and that the equilibrium pressure of the oxygen would rise rapidly with rise in temperature. These results and conclusions are in accord with most of the data on the effect of pressure on the decomposition of potassium chlorate.²

Fowler and Grant,³ however, suggested that the decomposition might be reversible; and Sodeau⁴ says of lead chlorate, "It seems remarkable

¹ A preliminary version of this article was received February 14, 1927.

^{1a} Lewis and Randall, "Thermodynamics and the Free Energy of Chemical Substances," McGraw-Hill Book Co., 1923, pp. 508-511.

² (a) Veley, *Phil. Trans.*, 179A, 257-295 (1888); (b) Warren, *Chem. News*, 58, 247 (1888).

³ Fowler and Grant, *J. Chem. Soc.*, 57, 272 (1890).

⁴ Sodeau, *J. Chem. Soc.*, 81, 1066 (1902).